

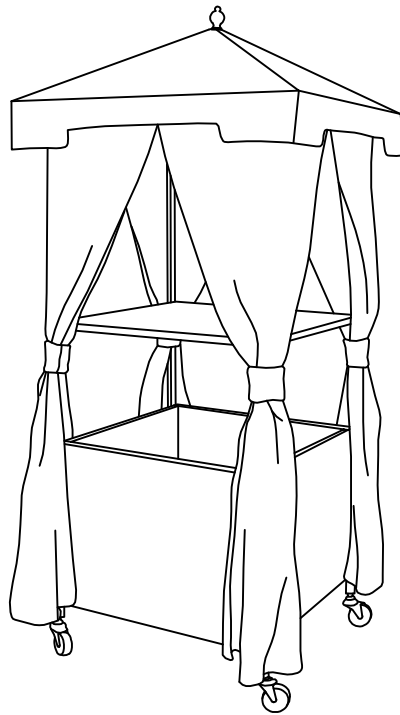

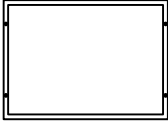







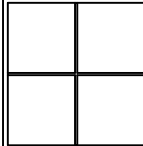
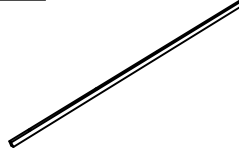
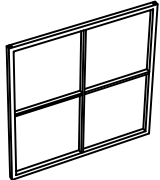
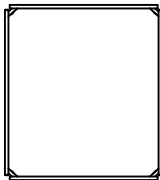
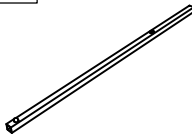

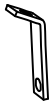

Outdoor Wicker Float Towel Valet
CO7304



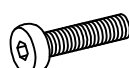

PART LIST

A 	B 	C 	D 	E 
Long Side Panel 2 PCS	Short Side Panel 2 PCS	Bottom Panel 1 PC	Long Post 4 PCS	Shelf 1 PC
F 	G 	H 	I 	J 
Top Frame 1 PC	Rib 4 PCS	Hub 1 PC	Connector 4 PCS	Finial 1 PC
K 	L 	M 	N 	
Locking Caster 2 PCS	Swivel Caster 2 PCS	Top Cover 1 PC	Fabric Curtain 1 PC	

HARDWARE LIST

#1 	#2 	#3 	#4 
M6*15mm	M6*40mm	M6mm	M6mm
Short Bolt 8 PCS	Long Bolt 28 PCS	Washer 36 PCS	Allen Key 1 PC

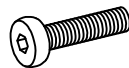
EXTRA HARDWARE LIST

#1 	#2 	#3 
M6*15mm	M6*40mm	M6mm
Short Bolt 2 PCS	Long Bolt 3 PCS	Washer 3 PCS

Step 1. Attach long side panels (part #A) to long posts (part #D) using the long bolts (part #2), washers (part #3) and allen key (part #4). Attach swivel casters (part #L) and locking casters (part #K) to long posts (part #D).

NOTE: Please do not fully tighten bolts until unit is fully assembled.

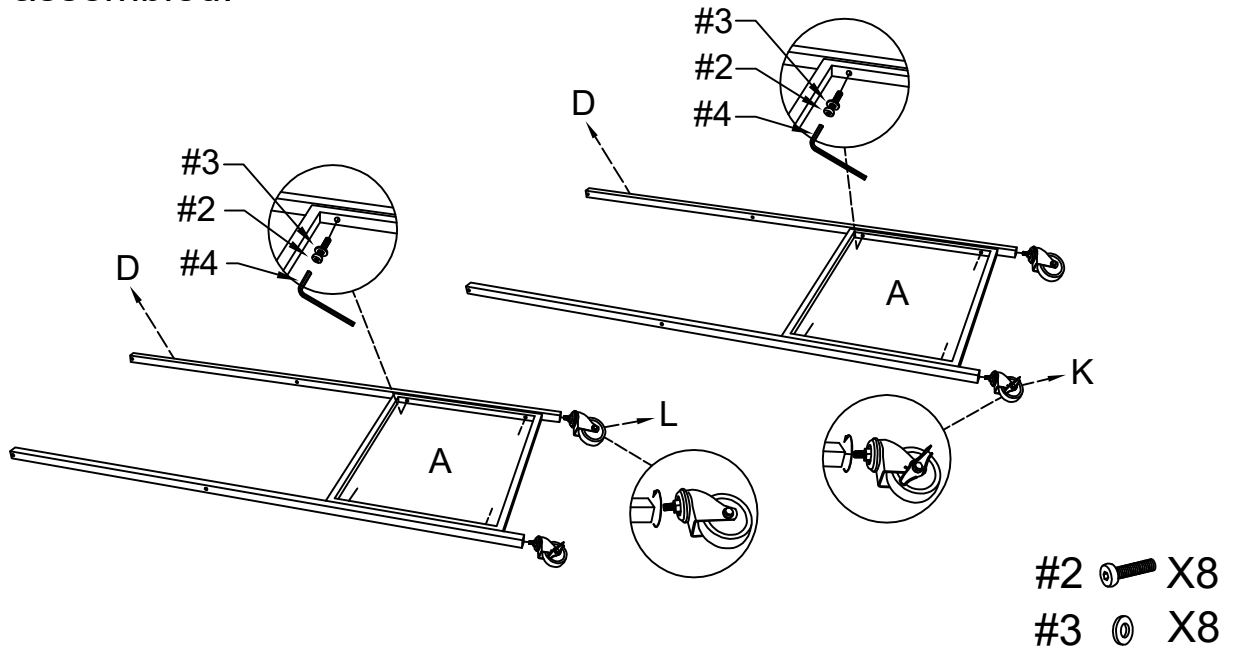

Step 2. Attach short side panels (part #B) to long side panels (part #A) of assembled parts (part #A,D,L&K) using long bolts (part #2), washers (part #3) and allen key (part #4).

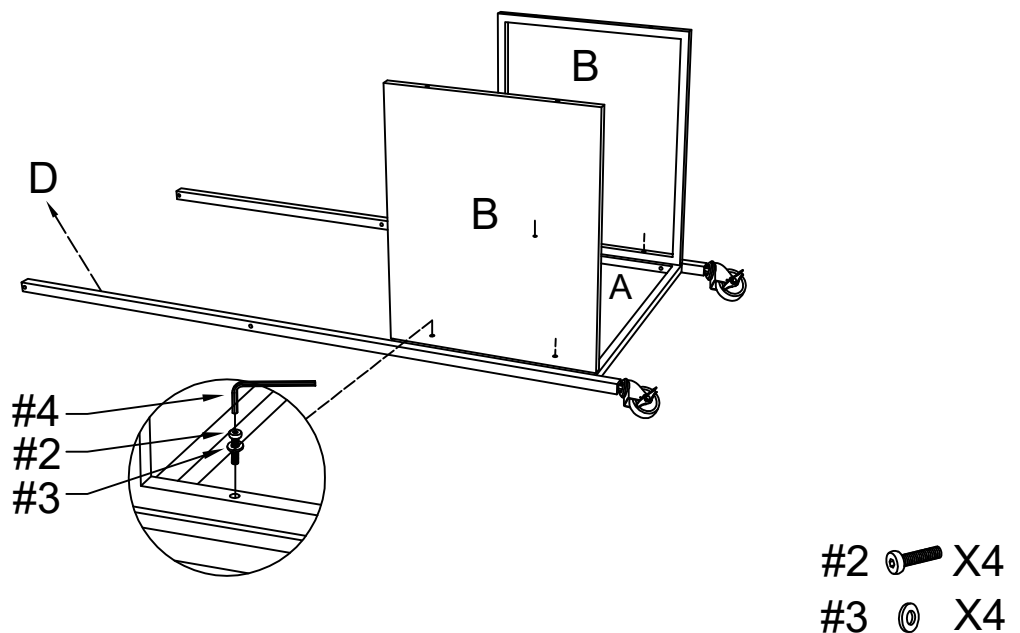

Step 3. Attach assembled parts (part #A,D,L&K) to short side panels (part #B) of assembled parts (part #A,B,D,L&K) using long bolts (part #2), washers (part #3) and allen key (part #4).

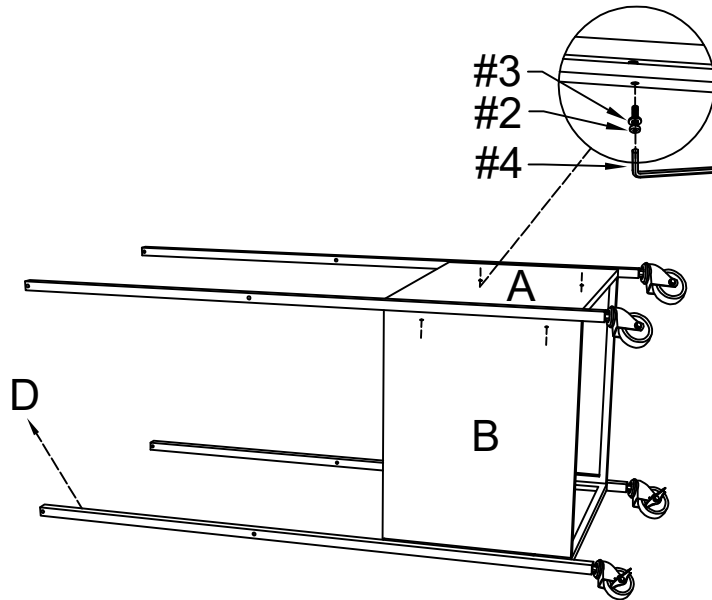

#2  X4

#3  X4

Step 4. Attach bottom panel (part #C) to short side panels (part #B) of assembled parts (part #A,B,D,L&K) using long bolts (part #2), washers (part #3) and allen key (part #4).

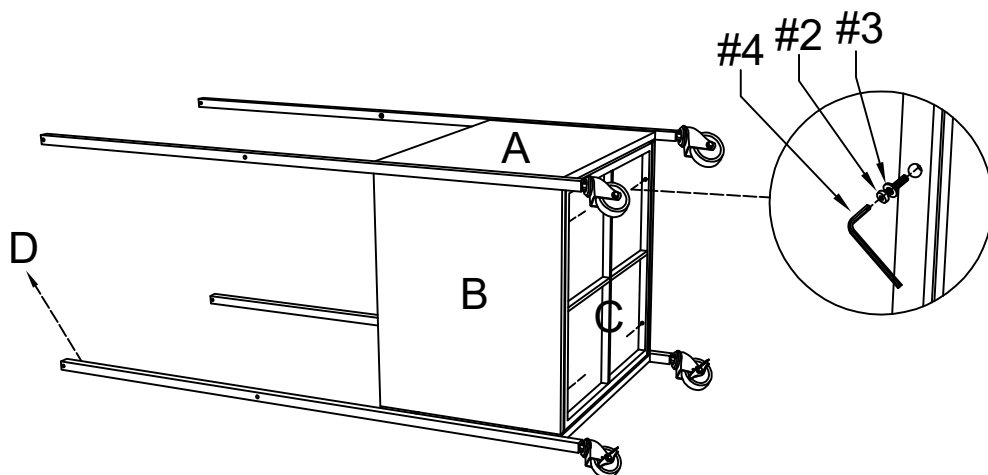

#2  X4

#3  X4

Step 5. Attach shelf (part #E) to long posts (part #D) of assembled parts (part #A,B,C,D,L&K) using long bolts (part #2), washers (part #3) and allen key (part #4).

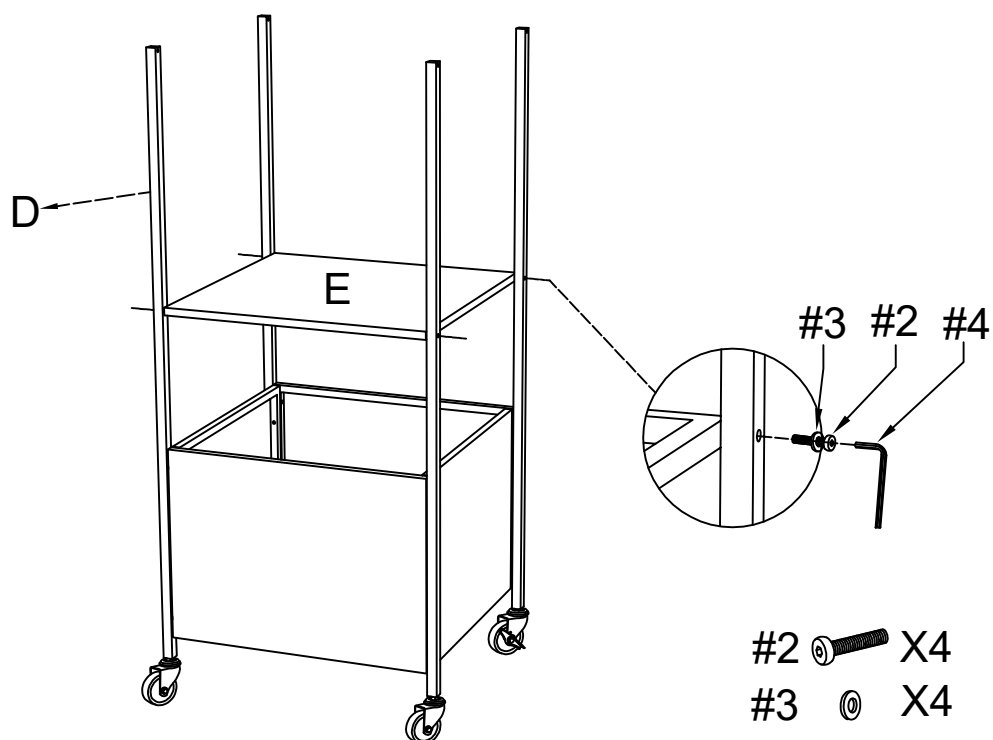

Step 6. Attach top frame (part #F) to long posts (part #D) of assembled parts (part #A,B,C,D,E,L&K) using long bolts (part #2), washers (part #3) and allen key (part #4).

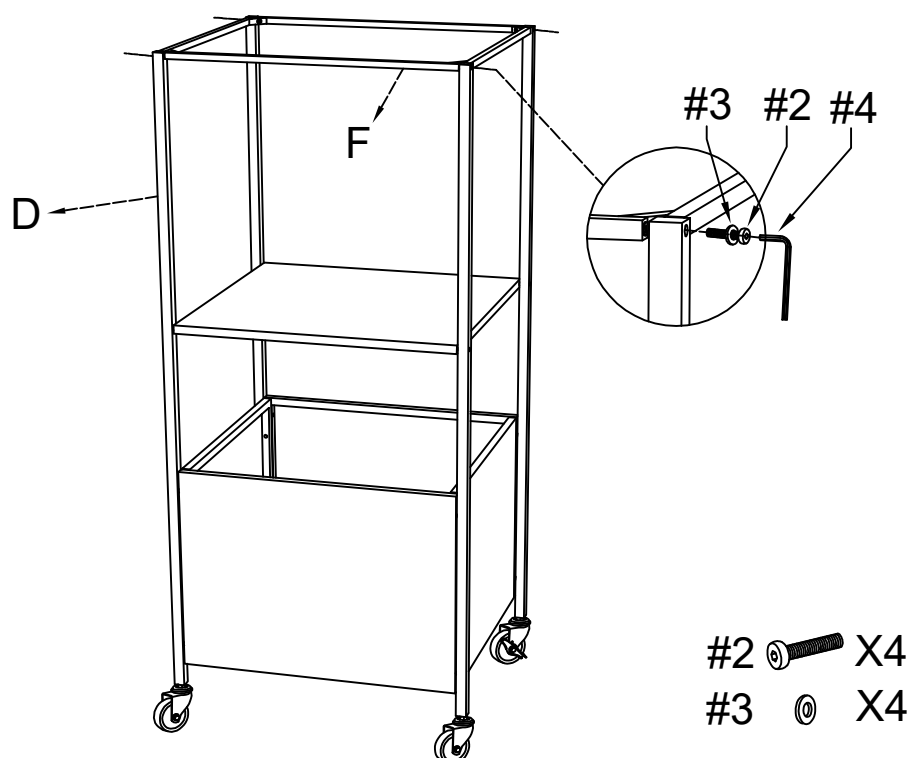

Step 7. Attach connectors (part #I) to top frame (part #F) of assembled parts (part #A,B,C,D,E,F,L&K) using short bolts (part #1), washers (part #3) and allen key (part #4).

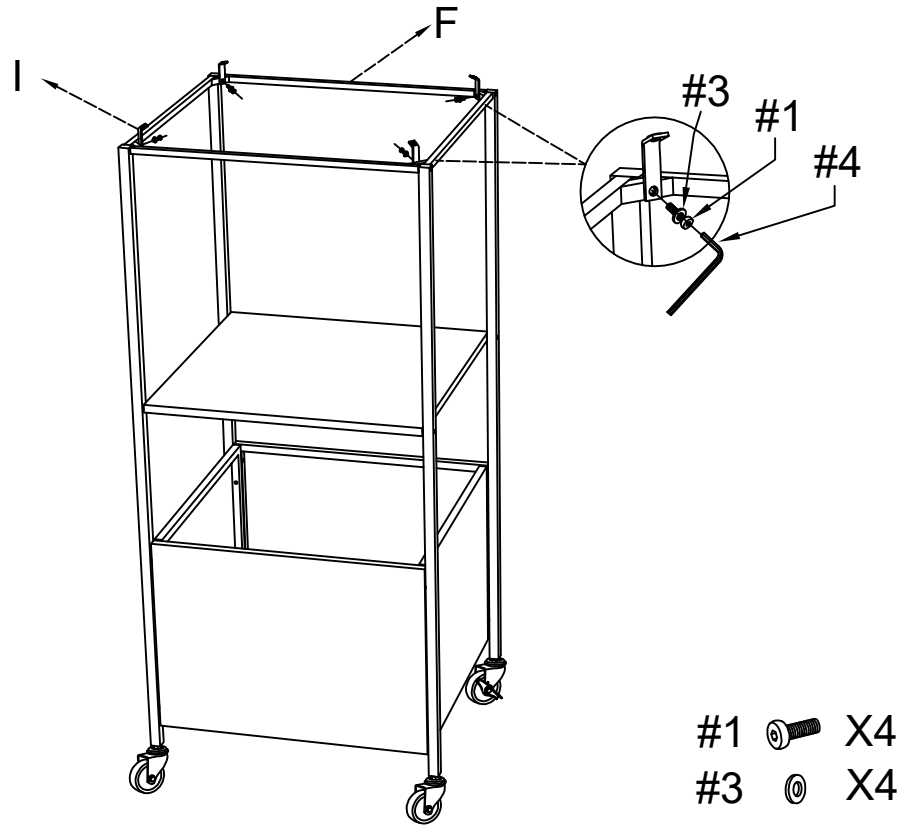

Step 8. Fully insert ribs (part #G) into the hub (part #H) until spring clips click into place.

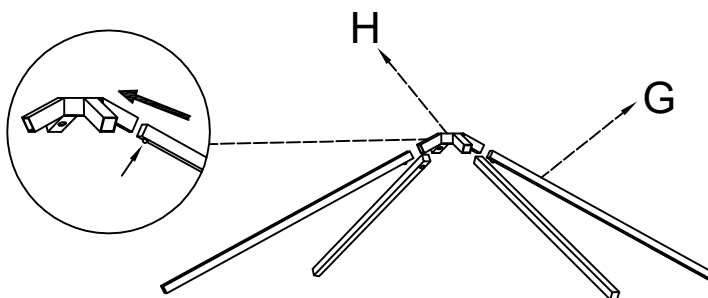

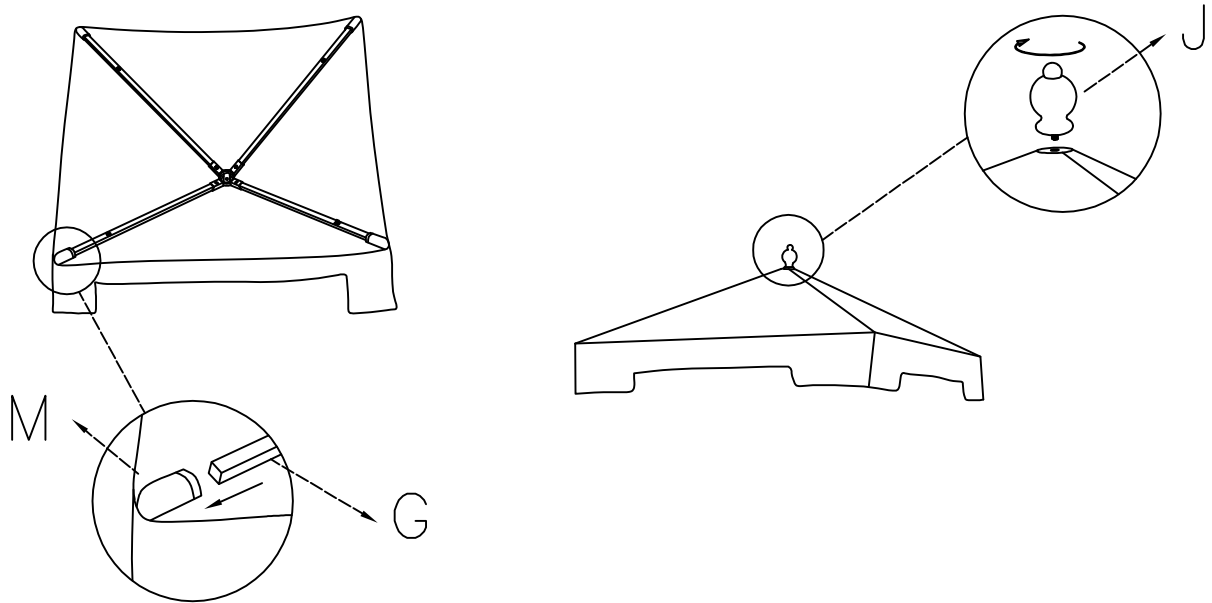

Step 9. Unfold top top cover (part #M) and attach to assembled parts (part #G&H) as shown below. Attach finial to hub (part #H) of assembled parts (part #G,H&M) to secure together.

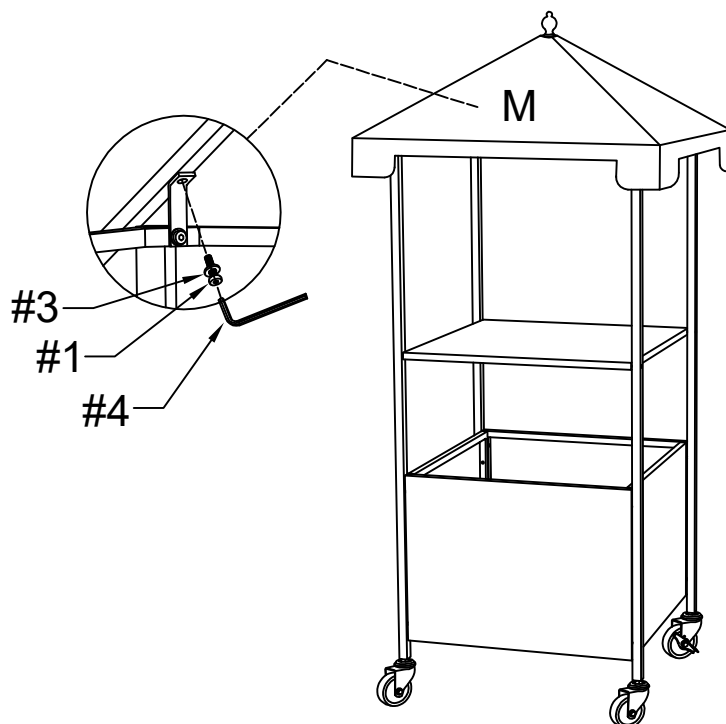

Step 10. Attach assembled parts (part #G,H,J&M) to connectors (part #I) of assembled parts (part #A,B,C,D,E,F,I,L&K) using short bolts (part #1), washers (part #3) and allen key (part #4).

NOTE: Please fully tighten all bolts at this time.



#1  X4
 #3  X4

Step 11. Secure fabric curtains (part #N) to top frame (part #F) of the completed unit with Velcro[®] straps as shown.

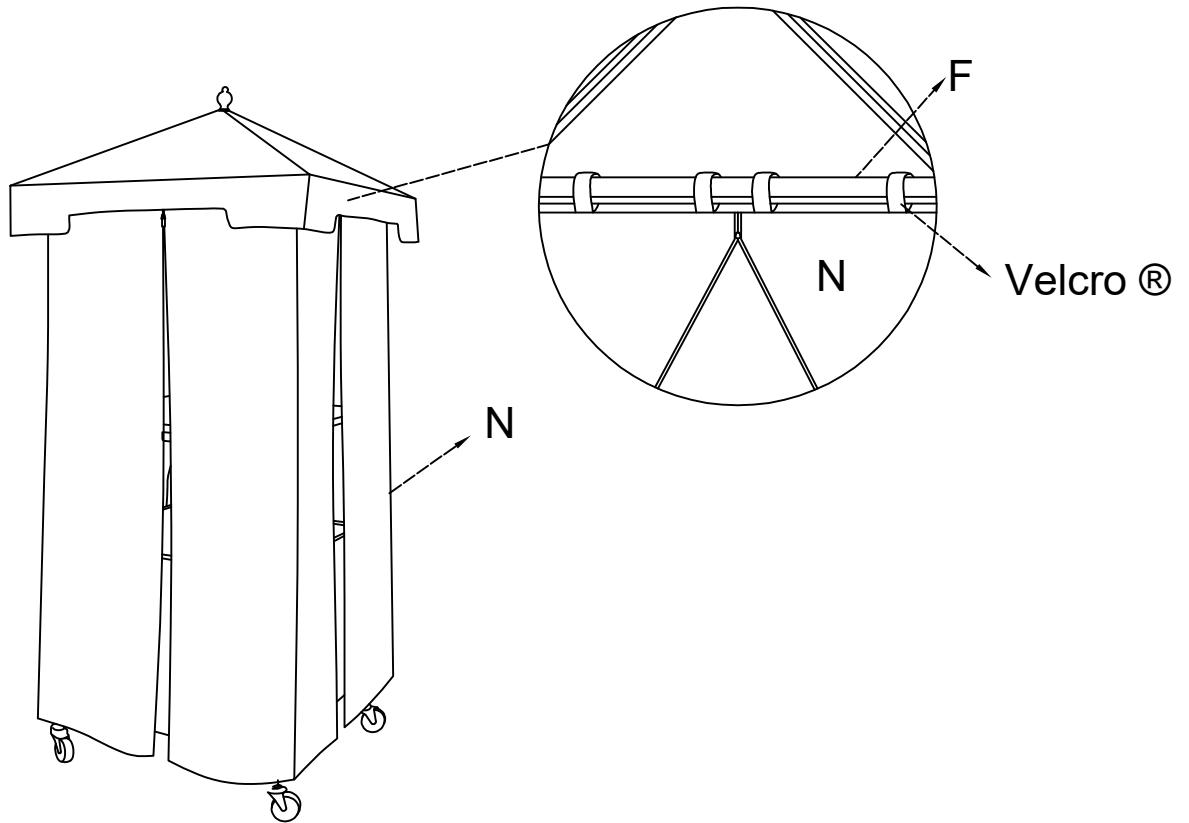

Step 12. NOTE: Curtains (part #N) can be held open by using the Velcro[®] straps to secure them to long posts (part #D) of the completed unit as shown below.

